

TECHNICAL DATA

TANDEM ROLLERS

BW 154 AP-4I, BW 174 AP-4F

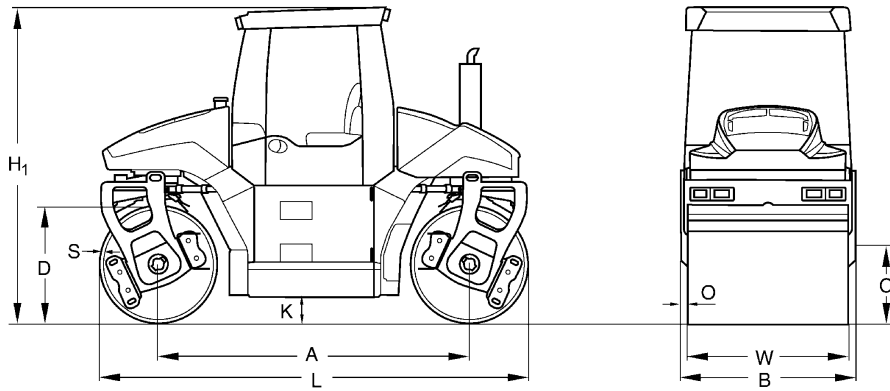



Dimensions in mm

	A	B	C	D	H1	K	L	O	S	W
BW 154 AP-4I	2890	1665	735	1100	2955	240	3990	72	16	1500
BW 174 AP-4F	3200	1826	660	1220	3000	288	4420	73	17	1680

Shipping dimensions in m3

BW 154 AP-4I
BW 174 AP-4F

with cabin

19,631
 24,213

Machine type	Compaction output (t/h) at different asphalt layer thicknesses		
	2-4 cm	6-8 cm	10-14 cm
BW 154 AP-4I	30-60	60-130	80-160
BW 174 AP-4F	50-110	90-180	140-210

Technical Data**BOMAG
BW 154 AP-4I****BOMAG
BW 174 AP-4F****Weights**

Operating weight CECE w. ROPS-cabin	kg	7.100	9.200
Axle load, front / rear CECE	kg	3.550/3.550	4.700/4.500
Static linear load, front / rear CECE	kg/cm	23,7/23,7	28,0/26,8
Grossweight	kg	8.600	10.800

Dimensions

Track radius, inner	mm	2.950	2.946
---------------------------	----	-------	-------

Driving Characteristics

Speed (1)	km/h	0 - 10,0	0- 10,5
-----------------	------	----------	---------

Drive

Engine manufacturer		Kubota	Deutz
Type		V3307 CR-T	TCD 3.6 L4
Emission stage		Stage IIIb / TIER4f	Stage IV / TIER4f
Exhaust gas aftertreatment		DOC+DPF	DPF+SCR
Cooling		water	Liquid
Number of cylinders		4	4
Fuel		diesel	diesel
Performance ISO 14396	kW	55,4	74,4
Performance SAE J 1995	hp	74,2	99,6
Speed	min-1	2.400	2.000
Split drum		front + rear	front + rear

Brakes

Service brake		hydrost.	hydrost.
Parking brake		mech.	mech.

Steering

Steering system		2-p. pivoted	2-p. pivoted
Lateral displacement right/left	mm	1.130	1.350

Exciter system

Frequency	Hz	40/55	45/60
Amplitude	mm	0,66/0,32	0,46/0,20
Centrifugal force	kN	69/63	80/61

Sprinkler System

Type of sprinkling		pressure	pressure
--------------------------	--	----------	----------

Capacities

Fuel	l	155,0	180,0
Water	l	550,0	680,0

Technical modifications reserved. Machines may be shown with options.

Standard Equipment

- ECOMODE
- Plastic water tank under the operator's platform
- Water-saving pressure sprinklers
- Individual vibration control
- 2 amplitudes / 2 frequencies
- Autom. vibration operation
- 4 spring-loaded hinged scrapers
- Indicator and hazard lights
- ROPS cabin with seat belts + heating
- 2 Outside mirrors
- Steering method/Operator's seat sliding / rotatable
- Steering with comfort control - 5 Steering modes
- Back-up alarm
- Emergency STOP
- Brake release device
- Split drums

Optional Equipment

- ECONOMIZER
- Edge cutter
- Rotary beacon
- Special paint
- Environmentally compliant hydraulic oil
- Tool kit
- Precision spreader
- Precision spreader laterally slidable
- Air condition
- Radio/Radio preparation
- Lighting for drum edge
- Backup warning buzzer with broadband technology
- Additional outside mirrors
- Asphalt temperature display
- By-pass filter
- BCM-Documentation system
- BOMAG TELEMATIC POWER
- Rearview camera
- BOMAG ECOSTOP

